



- Versione aggiornata di questo manuale
- Last version of this manual
- Dernière version du manuel
- Letzte Version des Handbuchs
- La última versión del manual
- Última versão do manual

IP2456•2024-06-10

BBK1500X1

Istruzioni kit batteria

Instructions pour le kit de batterie

Instrucciones del kit de batería

Battery kit instructions

Anweisungen für den Batteriesatz

Instruções do kit de bateria

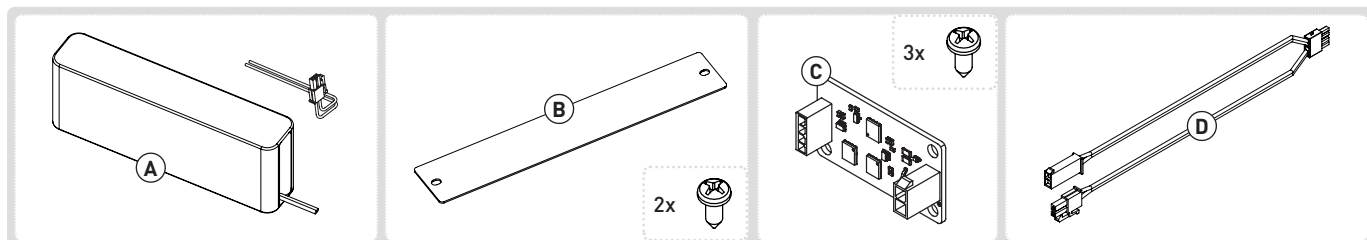

1. Descrizione / Description / Beschreibung / Descripción / Descrição

- Il BBK1500X1 gestisce la carica delle batterie con alimentazione da rete elettrica.
- The BBK1500X1 control the battery charge from electricity grid.
- Le BBK1500X1 contrôle la charge de la batterie à partir du réseau électrique.
- Die BBK1500X1 steuert die Batterieladung aus dem Stromnetz.
- El BBK1500X1 controla la carga de la batería desde la red eléctrica.
- O BBK1500X1 controla a carga da bateria a partir da rede eléctrica.

Modalità operativa / Working mode / Betriebsart / Mode de fonctionnement / Modo de funcionamiento / Modo de funcionamento	Descrizione / Description / Beschreibung / Descripción / Descrição
Batterie d'emergenza Battery back up Piles de secours Notfall-Batterien Baterías de emergencia Baterias de emergência	L'automazione prosegue il suo funzionamento in caso di black out di rete elettrica. Automation continues its operation in case of electricity grid black out. L'automatisation se poursuit en cas de panne du réseau électrique. Die Automatisierung setzt ihren Betrieb auch bei einem Stromausfall fort. La automatización sigue funcionando en caso de apagón de la red eléctrica. A automatização continua a funcionar em caso de corte da rede eléctrica.

2. Specifiche tecniche batterie / Batteries technical specifications / Spécifications de la batterie / Spezifikationen der Batterie / Especificaciones de la batería / Especificações da bateria

Tensione / Voltage / Tension / Spannung / Tensión / Tensão	24 V
Amperaggio / Amperage / Ampérage / Stromstärke / Amperaje / Amperagem	1500 mAh
Batteria / Battery / Batterie / Batterie / Batería / Bateria	1 x 20 AA cells - 24 V
Tipo / Type / Typ	NiMH
Dimensioni / Size / Taille / Größe / Talla / Tamanho	145 x 30 x 55 mm
Temperatura / Temperature / Température / Temperatur	-15° C / +50° C
Fusibile / Fuse / Fusible / Sicherung / Fusível	--

IT Le specifiche tecniche sono soggette a modifica senza preavviso.

DE Änderungen der Spezifikationen ohne Vorankündigung vorbehalten.

EN Technical data subject to change without notice.

ES Especificaciones sujetas a cambios sin previo aviso.

FR Les spécifications peuvent être modifiées sans préavis.

PT As especificações estão sujeitas a alterações sem aviso prévio.

3. Installazione BBK / BBK series installation / Installation du BBK BBK-Einbau / Instalación BBK / Instalação da BBK

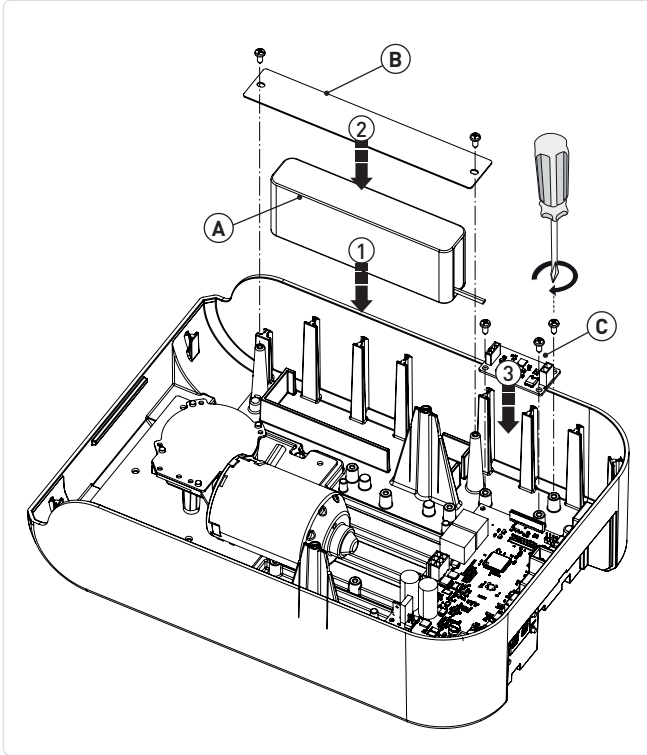

IT Dichiarazione CE di conformità
Il fabbricante ASSA ABLOY Entrance Systems AB con sede in Lodjursgatan 10, SE-261 44 Landskrona, Sweden dichiara che il tipo di apparecchiatura con nome BBK1500X1 - kit batterie, è conforme alle seguenti Direttive: 2011/65/UE (RoHS 2); 2015/863/UE (modifica RoHS 2).

FR Déclaration de conformité CE
Le fabricant ASSA ABLOY Entrance Systems AB, dont le siège est situé à Lodjursgatan 10, SE-261 44 Landskrona, Suède, déclare que le type d'équipement portant le nom BBK1500X1 - kit de batterie, est conforme aux directives suivantes : 2011/65/UE (RoHS 2) ; 2015/863/UE (RoHS 2 amendment).

TE EG-Konformitätserklärung
Der Hersteller ASSA ABLOY Entrance Systems AB mit Sitz in Lodjursgatan 10, SE-261 44 Landskrona, Schweden, erklärt, dass der Gerätetyp mit der Bezeichnung BBK1500X1 - Batteriesatz, mit den folgenden Richtlinien übereinstimmt: 2011/65/EU (RoHS 2); 2015/863/EU (RoHS 2 Änderung).

ES Declaración de conformidad CE
El fabricante ASSA ABLOY Entrance Systems AB con domicilio social en Lodjursgatan 10, SE-261 44 Landskrona, Suecia declara que el tipo de equipo con el nombre BBK1500X1 - kit de batería, cumple con las siguientes Directivas: 2011/65/UE (RoHS 2); 2015/863/UE (modificación RoHS 2).

PT Declaração CE de Conformidade
O fabricante ASSA ABLOY Entrance Systems AB, com sede social em Lodjursgatan 10, SE-261 44 Landskrona, Suécia, declara que o tipo de equipamento com o nome BBK1500X1 - kit de bateria, está em conformidade com as seguintes diretivas: 2011/65/UE (RoHS 2); 2015/863/UE (alteração RoHS 2).

EN EC and UK declaration of Conformity
The manufacturer, ASSA ABLOY Entrance Systems AB, with registered office at Lodjursgatan 10, E-261 44 Landskrona, Sweden declares that the type of equipment with name BBK1500X1 - batteries kit complies with the fundamental requisites and other relevant requirements laid down by:

EC directives	UK regulations
2011/65/UE (RoHS2)	The Restriction of the Use of Certain Hazardous Substances in Electrical and Electronic Equipment Regulations 2012 (RoHS).
2015/863/EU (RoHS2 Amendment)	

Origgio, 2024-02-20

Matteo Fino
(CEO Ditec)

4. Collegamenti elettrici / Electrical connections / Connexions électriques / Elektrische Anschlüsse / Conexiones eléctricas / Ligações eléctricas

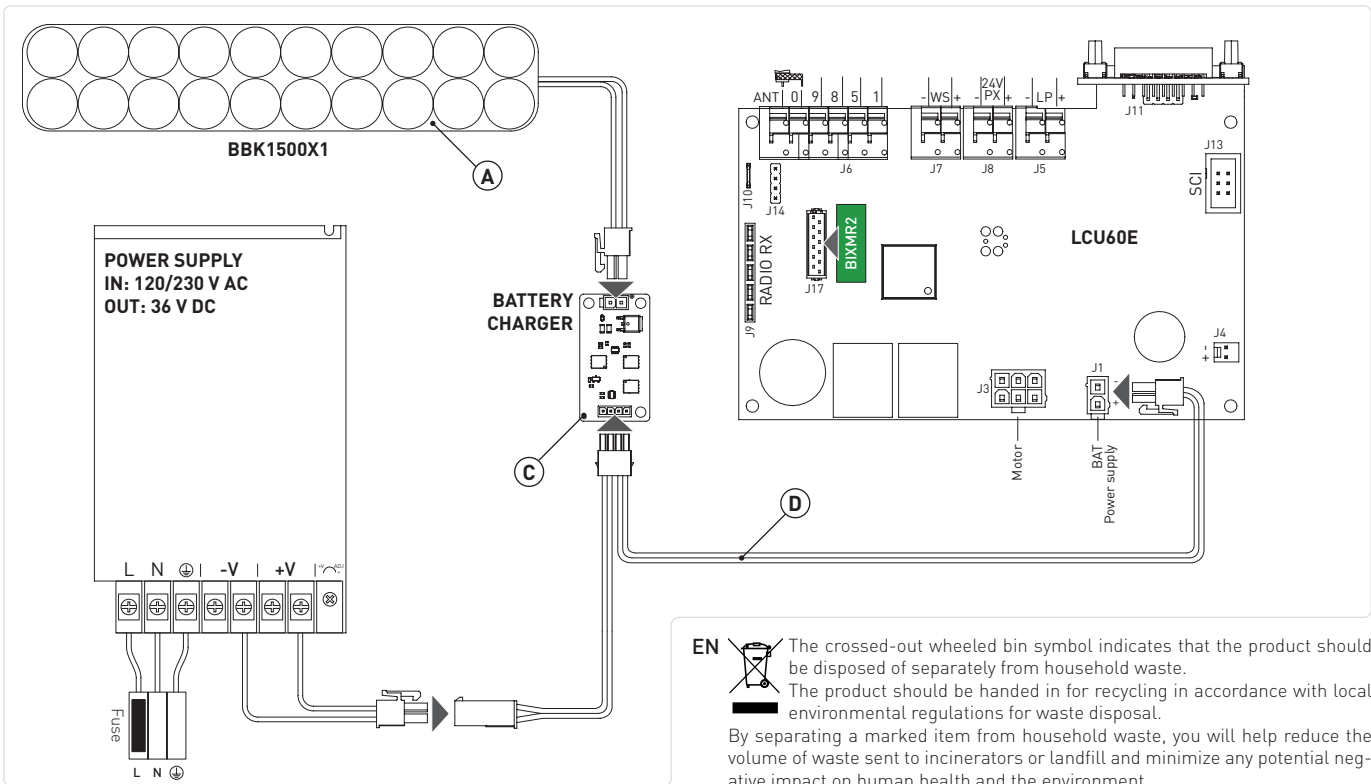

EN The crossed-out wheeled bin symbol indicates that the product should be disposed of separately from household waste.
The product should be handed in for recycling in accordance with local environmental regulations for waste disposal.
By separating a marked item from household waste, you will help reduce the volume of waste sent to incinerators or landfill and minimize any potential negative impact on human health and the environment.



ASSA ABLOY Entrance Systems AB
Lodjursgatan 10
SE-261 44, Landskrona
Sweden
© ASSA ABLOY